

Applicazione

Sono utilizzati per deviare il flusso a due utilizzi usando una sola alimentazione.

Montaggio

Collegare l'alimentazione alla bocca P e gli utilizzi alle bocche A e B.

Funzionamento

Ruotando la leva in pos.1 si alimenta la bocca A.

Ruotando la leva in pos.2 si alimenta la bocca B.

Tipo L (centro chiuso): con la leva in posizione centrale le bocche P, A e B sono parzialmente chiuse. La leva ruota di 90°.

Tipo T (centro aperto): con la leva in posizione centrale le bocche P, A e B sono completamente aperte. La leva ruota di 180°.

A richiesta

Cromatura - Zincatura verde - Leve speciali - Filetti metrici - Attacchi DIN2353 - Filettatura maschio.

NOTE COSTRUTTIVE

Corpo in acciaio zincato - Non ammette trafiletti - Ruota in pressione - Non accetta contropressioni sulla bocca chiusa.

Application

3 way ball valve is used to connect inlet flow to two ports or vice-versa. This special hydraulic scheme is able to control a single action actuator.

Installation

P Port is connected to inlet flow and A and B ports to actuator ports.

Operation

Hand lever in pos. 1 allows flow to A port.

Hand lever in pos. 2 allows flow to B port.

L Type (closed center): when hand lever is in the mid position all ports are partially closed. Hand lever turns 90° only.

T Type (open center): when hand lever is in the mid position all ports are completely open. Hand lever turns 180°.

Optional

Green zinc plated - Chromium plated - Special hand lever - Metric threads - DIN2353 fittings port thread - Male thread.

FEATURES

Steel body - Zinc plated - No leakage - Turns with max pressure - Counter pressure to closed port cannot be applied.

Centro chiuso
Closed center

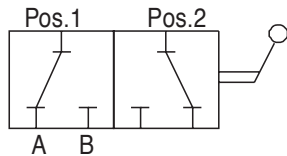

Centro aperto
Open center

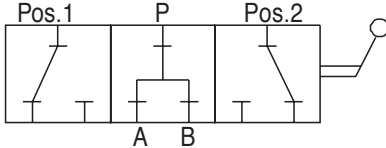

ESEMPIO D'ORDINAZIONE

Dimensione 03 - Attacchi filettati 1/2 GAS
- Tipo T

RSAP3V03 T

Dimensione 03 - Attacchi filettati 1/2 NPT
- Tipo L

RSAP3V03 N L

ORDERING CODE EXAMPLE

03 Dimension - 1/2 GAS Port thread
- T Type

RSAP3V03 T

03 Dimension - 1/2 NPT Port thread
- L Type

RSAP3V03 N L

Codice d'ordinazione - Ordering code

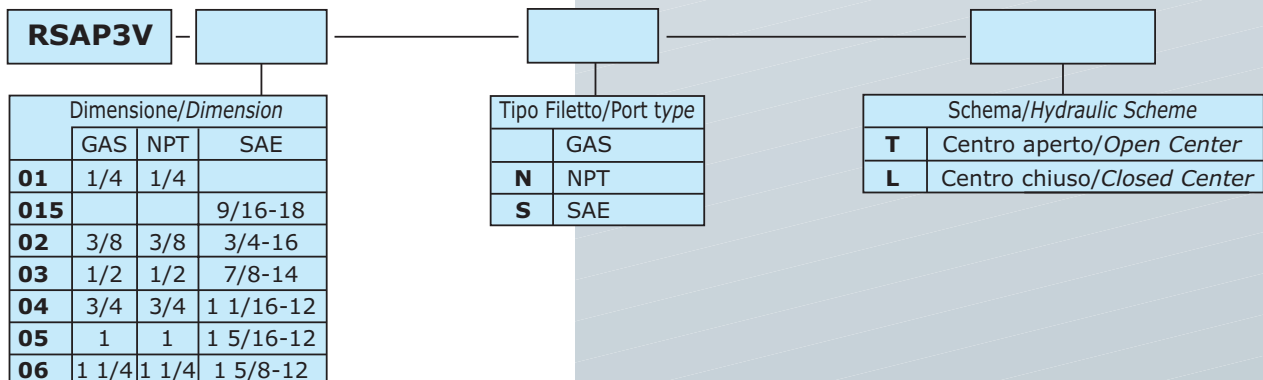

Caratteristiche - Hydraulic characteristics

Dimensione/Dimension	01	015	02	03	04	05	06
Pressione max/Max Pressure bar	380	380	380	320	300	280	240
Portata max/Max Flow l/min	30	30	50	80	120	160	160
Diametro nominale/Nominal Diameter mm	6	6	10	13	20	25	85

N.B.: per l'utilizzo di altri parametri vogliate consultarci

Note: if application needs other/specific parameters or measures please contact us

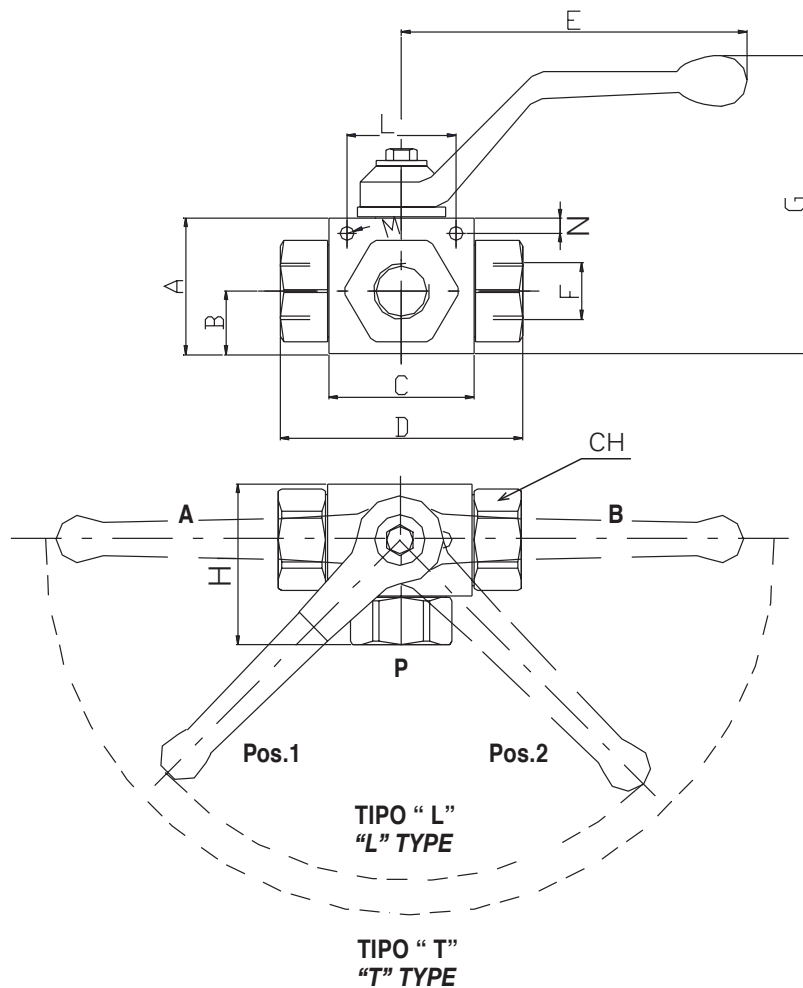
Dimensioni e pesi - External dimensions and weights

Dimensione/Dimension	A	B	C	D	E	F GAS	F NPT	F SAE	G	H	L	M	N	CH	Peso Weight kg
01	35	14.5	36	69	103	1/4	1/4		81	42	25	4.5	7	22	0.35
015	35	14.5	36	69	103			9/16-18	81	42	25	4.5	7	24	0.35
02	40	18	43	73	103	3/8	3/8	3/4-16	85	45	36	5.2	4	27	0.52
03	45	22	47	84	103	1/2	1/2	7/8-14	91	54	36		4	30	0.71
04	60	27	62	97	181	3/4	3/4	1 1/16-12	108	68	45		6.5	41	1.62
05	60	25.5	68	114	181	1	1	1 5/16-12	108	84	45	7	6.5	46	2.08
06	60	25.5	68	132	181	1 1/4	1 1/4	1 5/8-12	108	89	45	7	6.5	50	2.40